

Multilayer Chip Inductor for Choke – MCL Series

Operating Temp. : -40°C~+125°C

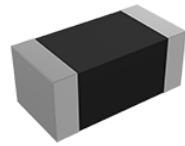

FEATURES

- Monolithic structure for high reliability
- Excellent solderability and high heat resistance
- No cross coupling due to magnetic shield
- High DC bias current due to developed material
- Low DC resistance

APPLICATIONS

- Choke circuits in DC power line of consumer electronics such as personal computers, mobile phones, digital video cameras, and music players

PRODUCT IDENTIFICATION

MCL

1608

S

1R0

M

I

①

②

③

④

⑤

⑥

①

Type	
MCL	Chip Inductor for Choke

②

External Dimensions (LxW) (mm)	
1608 [0603]	1.6x0.8
2012 [0805]	2.0x1.25

③

Feature Type	
S	Standard
H	Ir-Improved

④

Nominal Inductance	
Example	Nominal Value
1R0	1.0μH
※R= decimal point	

⑤

Inductance Tolerance	
M	±20%
N	±30%

⑥

Packing	
T	Tape & Reel

SHAPE AND DIMENSIONS

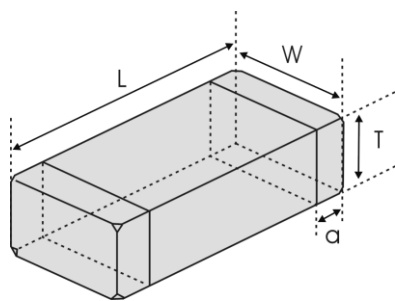

Unit: mm [inch]

Type	L	W	T	a
MCL1608 [0603]	1.6±0.15 [.063±.006]	0.8±0.15 [.031±.006]	0.8±0.15 [.031±.006]	0.3±0.2 [.012±.008]
MCL2012 [0805]	2.0 (+0.3, -0.1) [.079 (+.012, -.004)]	1.25±0.2 [.049±.008]	0.85±0.2 [.033±.008]	0.5±0.3 [.020±.012]
			1.25±0.2 [.049±.008]	

SPECIFICATIONS

MCL1608 TYPE

Part Number	Inductance	L Test Freq.	DC Resistance		Min. Self-resonant Frequency	Max. Rated Current	Thickness
Units	μH	MHz	Ω		MHz	A	mm [inch]
Symbol	L	Freq.	DCR		S.R.F	Ir*	T
			Max.	Typ.			
MCL1608SR10□T	0.1	1	0.182	0.140	240	0.70	0.8±0.15 [.031±.006]
MCL1608SR22□T	0.22	1	0.351	0.270	150	0.55	
MCL1608SR47□T	0.47	1	0.546	0.420	105	0.40	
MCL1608S1R0□T	1.0	1	0.260	0.200	75	0.19	
MCL1608S2R2□T	2.2	1	0.520	0.400	50	0.14	
MCL1608S4R7□T	4.7	1	0.780	0.600	35	0.10	
MCL1608S100□T	10	1	1.170	0.900	20	0.05	

MCL2012 TYPE

Part Number	Inductance	L Test Freq.	DC Resistance		Min. Self-resonant Frequency	Max. Rated Current	Thickness
Units	μH	MHz	Ω		MHz	A	mm [inch]
Symbol	L	Freq.	DCR		S.R.F	Ir*	T
			Max.	Typ.			
MCL2012SR10□T	0.1	1	0.091	0.070	235	1.00	0.85±0.2 [.033±.008]
MCL2012SR22□T	0.22	1	0.169	0.130	170	0.80	
MCL2012SR47□T	0.47	1	0.234	0.180	125	0.55	
MCL2012S1R0□T	1.0	1	0.260	0.200	75	0.30	
MCL2012S2R2□T	2.2	1	0.364	0.280	50	0.22	
MCL2012S4R7□T	4.7	1	0.390	0.300	25	0.18	
MCL2012S100□T	10	1	0.650	0.500	15	0.06	1.25±0.2 [.049±.008]
MCL2012H100□T	10	1	0.650	0.500	20	0.10	

※ □: Please specify the inductance tolerance code (M=±20%, N=±30%);

※ *: The rated current is the value of DC current at which the inductance value is dropped within 50% with the application of DC bias.

TYPICAL ELECTRICAL CHARACTERISTICS

Inductance vs. Frequency Characteristics

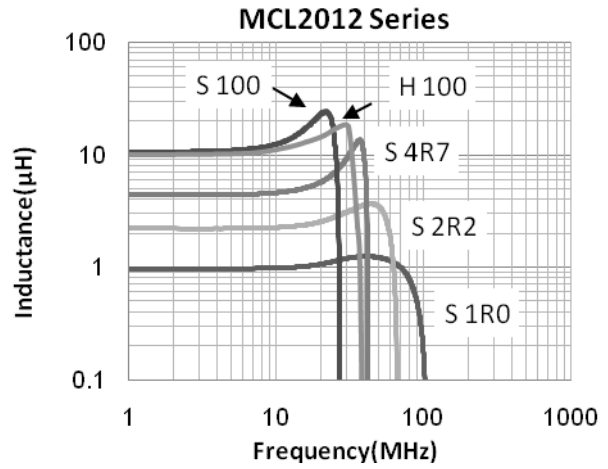
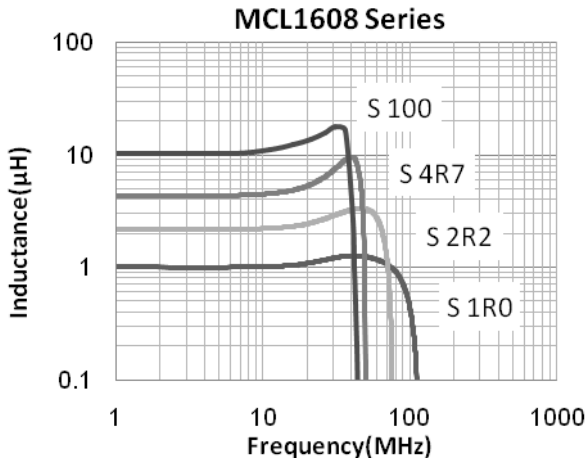

Impedance vs. Frequency Characteristics

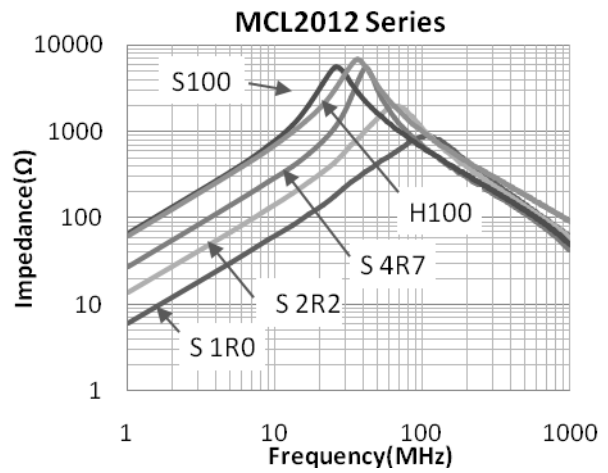
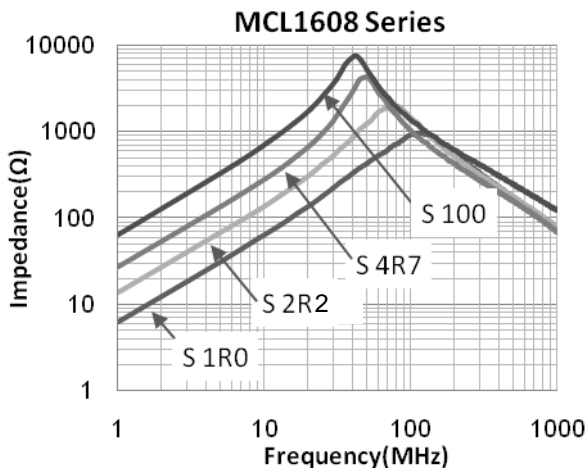

Inductance vs. DC Current Characteristics

