

**SMD QUARTZ CRYSTAL RESONATOR**

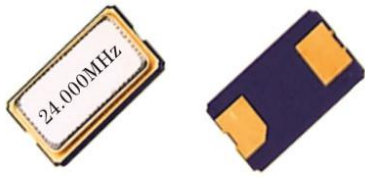

**2 Pad Version 5.0×3.2 mm**

- ±10 ppm type available
- Excellent Reliability Performance
- Reflow soldering temperature: 260°C max
- Ceramic Seam Weld package



RoHS compliant

**★ PARAMETERS**

PARAMETERS	SPECIFICATION
Frequency Range	8~50MHz
Operation Mode	Fundamental
Loading Capacitance	20pF Std. 8 to 32pF Series available
Drive Level	100 μ W (300 μ W Max)
Frequency Tolerance	±10ppm~±30ppm (at 25°C)
Equivalent Resistance	100 Ω Max
Frequency Stability	±10ppm~±50ppm
Operating Temp. Range:	-10~+60°C to -40~+85°C
Storage Temp. Range:	-55~+125°C

○ All specification subject change without notice.

**★ FREQUENCY STABILITY VS. TEMPERATURE**

Operation Temperature Range	Frequency Stability					
	±5ppm	±10ppm	±15ppm	±20ppm	±30ppm	±50ppm
-10°C~+60°C		●	○	●	○	○
-20°C~+70°C		○	○	●	○	○
-40°C~+85°C				○	●	○

● standard ○ available

**★ ESR (SERIES RESISTANCE RS)**

Frequency	Vibration Mode	ESR
8-9.999MHz	AT CUT/FUND.	100Ω(MAX)
10-11.999MHz	AT CUT/FUND.	60Ω(MAX)
12-15.999MHz	AT CUT/FUND.	50Ω(MAX)
16-24.999MHz	AT CUT/FUND.	40Ω(MAX)
25-50.000MHz	AT CUT/FUND.	30Ω(MAX)

**★ DIMENSIONS & LAND PATTERN LAYOUT (Unit: mm)**

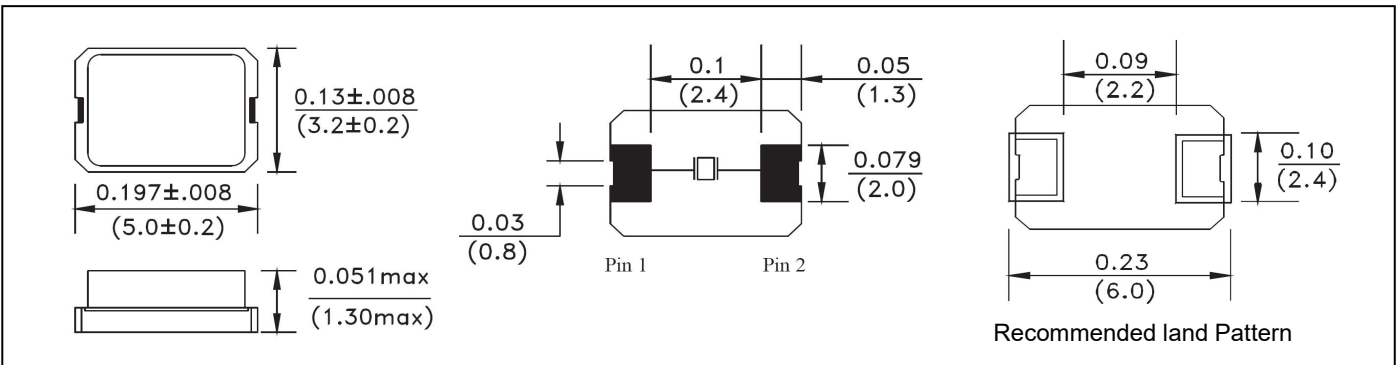

**★ PART NUMBER GUIDE** e.g. *FTX12.000M20SM5A-30/30B* (\*SM5A=5.0×3.2 SMD SEAM 2PAD TYPE)

Logo	Quartz Crystal Resonator	Frequency Hz	Load Capacitance pF	Package	Frequency Tolerance ppm	Frequency Stability ppm	Operating Temp. Range
FT	X	12.000M	20	SM5A	30	30	B

Definition	Description
Operating Temperature Range	A: -10~+60℃
	B: -20~+70℃
	C: -30~+80℃
	D: -40~+85℃
	E: Customer specified

★ TAPING SPECIFICATION (Unit: mm)

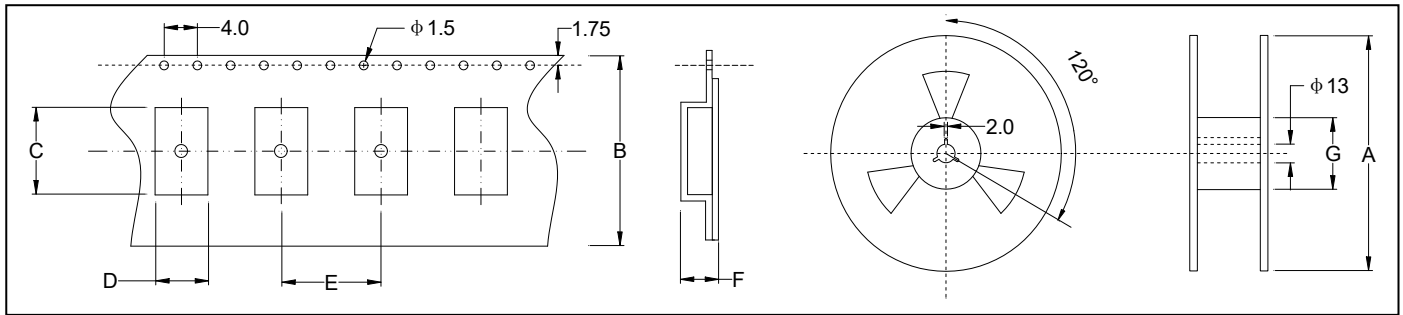

	A	B	C	D	E	F	G
SMD5032-2pad	178±2.0	12.0±0.3	5.40±0.10	3.60±0.10	8.0±0.1	1.1±0.1	60.5±1.0
1000 pcs per reel							

★ REFLOW SOLDERING PROFILE

