

SMD QUARTZ CRYSTAL RESONATOR

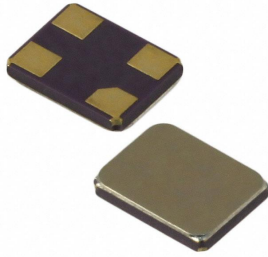

4 Pad Version 2.5×2.0 mm

- ±10 ppm type available
- Excellent Reliability Performance
- EMI shielding possible by grounded lid
- Reflow soldering temperature: 260°C max
- Ceramic Seam Weld package



RoHS compliant

★ PARAMETERS

PARAMETERS	SPECIFICATION
Frequency Range	16~60MHz
Operation Mode	Fundamental
Loading Capacitance	9pF Std. 8 to 32pF / Series available
Drive Level	10 μ W (100 μ W Max)
Frequency Tolerance	±10ppm~±30ppm (at 25°C)
Equivalent Resistance	80 Ω Max
Frequency Stability	±10ppm~±50ppm
Operating Temp. Range	-10~+60°C to -40~+85°C
Storage Temp. Range	-55~+125°C

○ All specification subject change without notice.

★ FREQUENCY STABILITY VS. TEMPERATURE

Operation Temperature Range	Frequency Stability				
	±10ppm	±15ppm	±20ppm	±30ppm	±50ppm
-10°C~+60°C	●	○	○	○	○
-20°C~+70°C	○	○	●	○	○
-40°C~+85°C		○	○	●	○

● standard ○ available

★ ESR (SERIES RESISTANCE RS)

Frequency	Vibration Mode	ESR
16-21.999MHz	AT CUT/FUND.	80Ω(MAX)
22-24.999MHz	AT CUT/FUND.	70Ω(MAX)
25-29.999MHz	AT CUT/FUND.	60Ω(MAX)
30-60.000MHz	AT CUT/FUND.	50Ω(MAX)

★ DIMENSIONS& LAND PATTERN LAYOUT (Unit: mm)

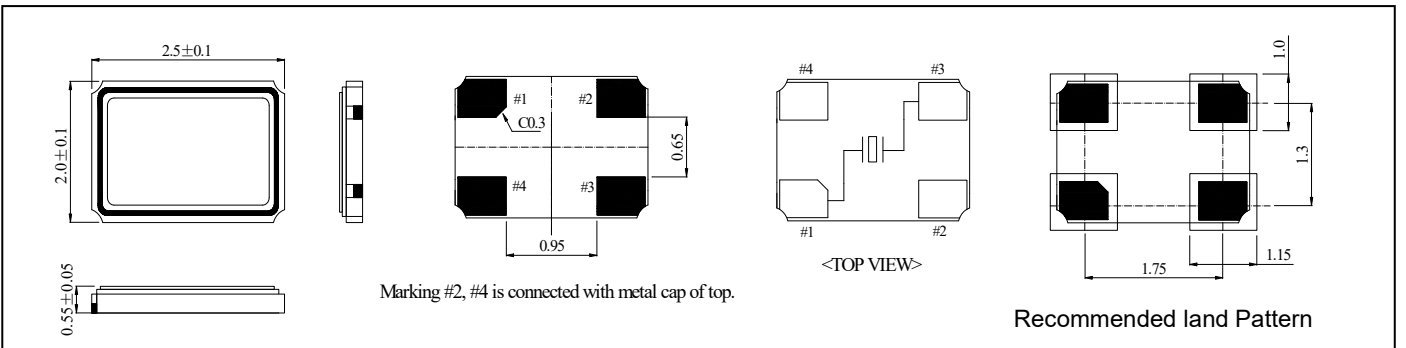

★ PART NUMBER GUIDE e.g. FTX16.000M10SM2S-10/10B (*SM2S=2.5×2.0 SMD SEAM TYPE)

Logo	Quartz Crystal Resonator	Frequency Hz	Load Capacitance pF	Package	Frequency Tolerance ppm	Frequency Stability ppm	Operating Temp. Range
FT	X	16.000M	10	SM2S	10	10	B

Definition	Description
Operating Temperature Range	A: -10~+60°C
	B: -20~+70°C
	C: -30~+80°C
	D: -40~+85°C
	E: Customer specified

★ TAPING SPECIFICATION (Unit: mm)

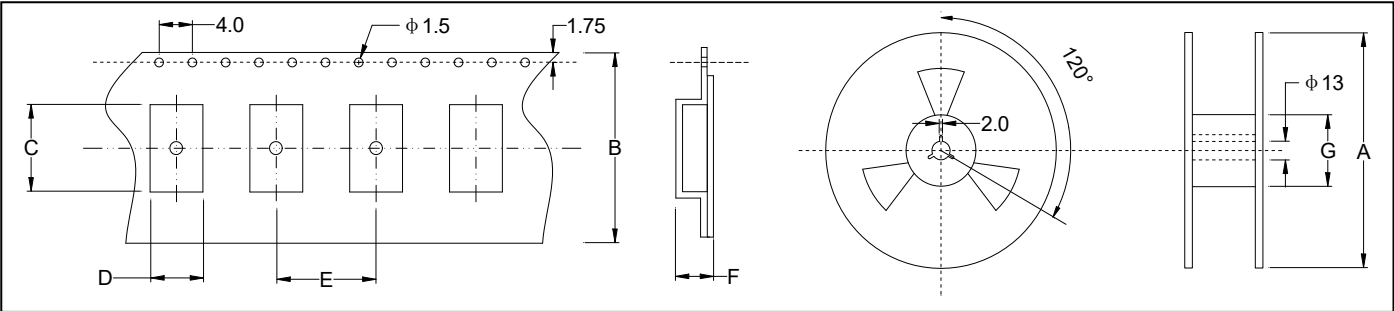

	A	B	C	D	E	F	G
SMD2520	178±2.0	8.0±0.3	2.70±0.05	2.25±0.05	4.0±0.1	0.65±0.05	60.5±1.0
3000 pcs per reel							

★ REFLOW SOLDERING PROFILE

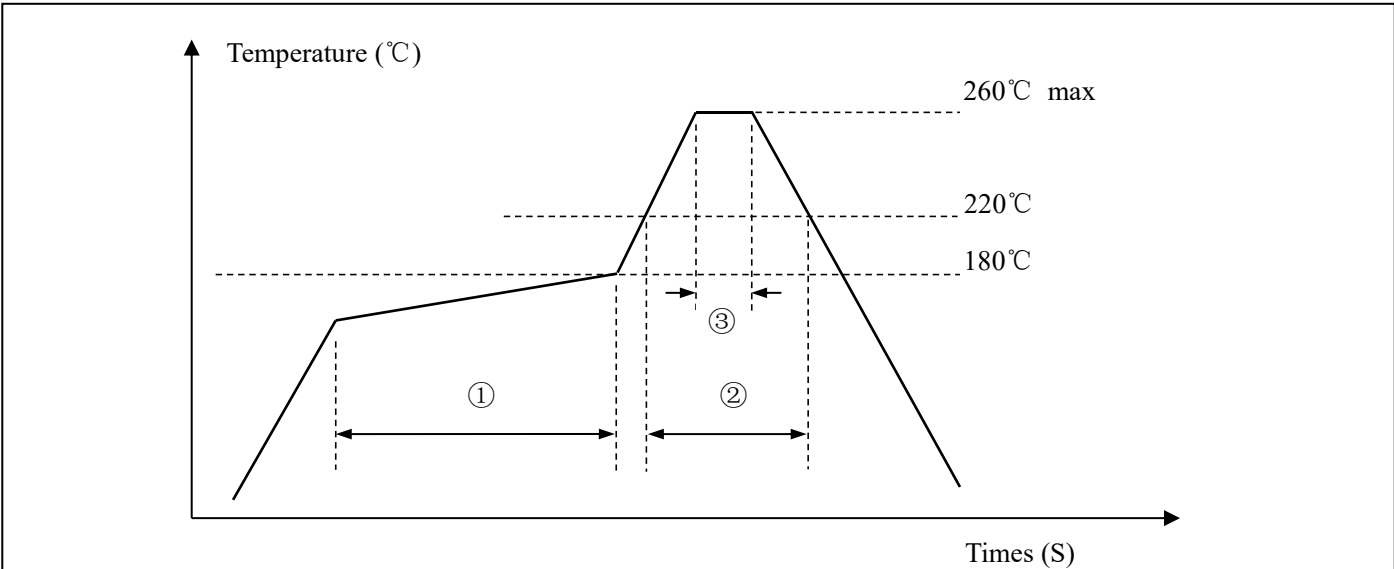

Pb free reflow A	①	Preheat	160~180°C	120sec. max
	②	Primary heat	220°C	60sec. max
	③	Peak	260°C	10sec. max.